



ITT

Lowara

de	TAUCHMOTORPUMPEN BAUREIHE Z8, ZR8, Z10, ZR10, Z12, ZR12	Installations- und Bedienungsanleitung Originalbetriebsanleitung
fr	POMPES IMMERGEES SÉRIE Z8, ZR8, Z10, ZR10, Z12, ZR12	Instructions pour l'installation et l'emploi Traduction de la notice d'exploitation originale
en	SUBMERSIBLE PUMPS Z8, ZR8, Z10, ZR10, Z12, ZR12 SERIES	Installation and Operating Instructions Translation of the Original Operation Manual
it	POMPE SOMMERSE SERIE Z8, ZR8, Z10, ZR10, Z12, ZR12	Istruzioni d'installazione e uso Traduzione del manuale d'uso
es	BOMBAS SUBMERGIBLES BAUREIHE Z8, ZR8, Z10, ZR10, Z12, ZR12	Manual de instrucciones Traducción del Manual de funcionamiento original
pt	BOMBAS SUBMERSÍVEIS SÉRIE Z8, ZR8, Z10, ZR10, Z12, ZR12	Manual de Instruções de Operação Tradução do manual de utilização original



de Das Handbuch muss für zukünftige Konsultationen sorgfältig aufbewahrt werden
fr Conservez avec soin le manuel pour toute consultation future
en Keep this manual for future reference
it Conservate con cura il manuale per future consultazioni
es Guardar con cuidado el manual para poderlo consultar en el futuro
pt Conservar cuidadosamente o manual para consultas futuras

Engineered for life

cod. 771072101 10/10

Table of Contents

1. General	27	4.8 Motor Filling.....	31
1.1 Foreword	27	4.9 Lowering the unit.....	31
1.2 Guarantee.....	27	4.10 Dismantling	32
1.3 Safety regulations.....	27	5. Electrical connection	32
1.4 Safety instructions	27	5.1 Electrical Devices.....	32
2. Description	29	5.2 Connecting the Cable	32
2.1 Models	29	6. Start-up, Operation, Shut down	32
2.2 Pipe Connection	29	6.1 Operation and Monitoring	33
2.3 Bearings	29	6.2 Limits of Operation.....	33
2.4 Motor	29	6.3 Shutting down	34
3. Transport, Handling, Storage	29	7. Maintenance, Servicing	34
3.1 Transport, Handling.....	29	8. Longer periods of non-operation	34
3.2 Storage	30	9. Faults - Causes and Solutions	34
4. Assembly, Operation	30	10. Repairs	35
4.1 Preparing to install the unit	30	11. Spare parts, Reserve pumps	35
4.2 Setting the Installation Depth.....	30	11.1 Spare parts	35
4.3 Pipes.....	30	11.2 Reserve pumps.....	36
4.4 Coupling the Motor and Pump.....	30		
4.5 Voltage and Frequency.....	31		
4.6 Cables	31		
4.7 Measuring insulation value	31		

1. General

1.1 Foreword

This product complies with the safety requirements of EC Machinery Directive 2006/42/EC.



The staff employed on installation, operation, inspection and maintenance must be able to prove that they know about the relevant accident prevention regulations and that they are suitably qualified for this work. If staff does not have the relevant knowledge, they should be provided with suitable instruction.

The operating safety of the system is only guaranteed if it is used in accordance with the provisions given in the confirmation of order and/or Point 4 in "Assembly, Operation".

The operator is responsible for following the instructions and complying with the safety requirements given in these Operating Instructions.

Smooth operation of the system can only be achieved if installation and maintenance are carried out carefully in accordance with the rules generally applied in the field of engineering and electrical engineering.

If not all the information can be found in these Operating Instructions, please contact us.

The manufacturer takes no responsibility for the pump or pump unit if the Operating Instructions are not followed.

These Operating Instructions should be kept in a safe place for future use.

If this system is handed on to any third party, it is essential that these Operating Instructions and the operating conditions and working limits given in the Confirmation of Order are also passed on in full.

These Operating Instructions do not take into account all design details and variants nor all the possible chance occurrences and events which might happen during installation, operation and maintenance.

Alterations or changes to the machine are only permitted by agreement with the manufacturer. Original spare parts and accessories authorised by the manufacturer should be used for greater safety. We bear no responsibility for the consequences of using other parts.

We retain all copyright in these Operating Instructions; they are intended only for personal use by the owner of the pump or the pump unit. The Operating Instructions contain technical instructions and drawings which may not, as a whole or in part, be reproduced, distributed or used in any unauthorised way for competitive purposes or passed on to others.

1.2 Guarantee

The guarantee is given in accordance with our Conditions of Delivery and/or the confirmation of order.

Repair work during the guarantee period may only be carried out by us, or subject to our written approval. Otherwise the guarantee ceases to apply.

Longer-term guarantees basically only cover correct handling and use of the specified material. Wear and tear, parts that are subject to wear such as impellers,

mechanical seals or packing, shaft seals, shafts, shaft sleeves, bearings, split rings and wear rings etc., as well as damage caused during transport or as a result of improper storage are not covered by the guarantee. In order for the guarantee to apply, it is essential that the pump or pump unit is used in accordance with the operating conditions given on the type plate and in the confirmation of order. This applies particularly for the endurance of the materials as well as the smooth running of the pump. If one or more aspects of the actual operating conditions are different, we should be asked to confirm in writing that the pump is suitable.

1.3 Safety regulations

These Operating Instructions contain important instructions which must be followed when the pump is assembled and commissioned and during operating and maintenance. For this reason, these Operating Instructions must be read by the skilled staff responsible and/or by the operator of the plant before it is installed and commissioned, and they must be left permanently ready at hand at the place where the plant is in use. The operator must ensure that the contents of the Operating Instructions are fully understood by the staff. These Operating Instructions do not refer to the General Regulations on Accident Prevention or local safety and/or operating regulations. The operator is responsible for complying with these (if necessary by calling in additional installation staff). The safety instructions contained in these Operating Instructions have the following special safety markings as specified in DIN 4844:



Warning against possible damage to property or the environment.



Warning against personal accidents which could occur if the safety instructions given in this part of the Operating Instructions are not followed.



Warning against dangerous electrical voltage.

It is absolutely essential that safety information affixed directly to the pump or pump unit is followed and maintained so that it is always easily legible.

1.4 Safety instructions

Dangers of not following safety instructions

Failure to follow the safety instructions can result in the following, for example:

- People being at risk because of electrical, mechanical and chemical factors.
- Important functions of the pump or pump unit failing.

Safety instructions for the operator

- Depending on the operating conditions, wear and tear, corrosion or age will limit the working life of the pump/pump unit, and its specified

characteristics. The operator must ensure that regular inspection and maintenance are carried out so that all parts are replaced in good time which would otherwise endanger the safe operation of the system. If abnormal operation or any damage are observed, the pump must cease operation immediately.

- If the breakdown or failure of any system or unit could lead to people being hurt or property being damaged, such system or unit must be provided with alarm devices and/or spare modules, and they should be tested regularly to ensure that they function properly.
- If dangerous media (e.g. explosive, toxic, hot) leak out (e.g. from shaft seals), these must be directed away so that there is no danger to people or the environment. The provisions of the law must be observed.
- Measures should be taken to exclude any danger from electricity (e.g. by complying with the local regulations on electrical equipment). If work is carried out on live electrical components, they should be unplugged from the mains or the main switch turned off and fuse unscrewed. A motor protection switch is to be provided.
- Basically, all work on the pump or pump unit should only be carried out when the pump is stationary and not under pressure. All parts must be allowed to return to ambient temperature. Make sure that no-one can start the motor during such work. It is essential that the procedure for stopping the system described in the Operating Instructions is observed. Pumps or pump systems that carry media that are dangerous to health must be decontaminated before being taken apart. Safety Data Sheets for the various liquids handled. Immediately the work has been completed, all safety and protective devices must be replaced or restarted.
- Under EC Machinery Directives, every machine must be fitted with one or more emergency command devices by which situations which represent an immediate danger or which could later be dangerous can be avoided. This does not include machines in which the emergency switches cannot reduce the danger, either because they do not reduce the time required to stop the machine or because they do not allow the measures required by the danger to be taken. This emergency switch must:
 - have controls that are clearly marked, easy to see and within easy reach;
 - stop the dangerous movement as quickly as possible without causing any additional danger;
 - trigger any specified safety movements or allow these to be started up.If the emergency command device is no longer operated after an emergency "off" switch has been triggered, this must be maintained by blocking the emergency command device until it is released again. It should not be possible to block the device without this triggering an emergency "off" switch. It should only be possible to release the device through an appropriate action; this release should

not start the machine up again - it should only make it possible to start it up again.

- If the power supply is interrupted or restored after being interrupted or if it is changed in any other way, this should not cause any danger (e.g. pressure surges).

Speed, Pressure, Temperature

Appropriate safety measures must be taken at the plant to ensure that the speed, pressure and temperature of the pump do not exceed the limit values given in the confirmation of order. In addition the plant must be protected against pressure surges such as can be caused by starting and switching off the plant too quickly (by suitably sized air vessel, non-return valve, starting valve or soft starter). Please remember that in the event of power failure soft starters and valves, for example, have no protection against pressure surges.

Flow level and NPSH

When entering the impeller, the liquid being handled must have a minimum pressure NPSH to prevent cavitation or breaking off of flow. This requirement is met if the unit NPSH value (NPSHA) is well above the pump NPSH value (NPSHR) under all operating conditions.

If the value falls below the pump NPSH value, this can lead to damage resulting from cavitation or serious damage from overheating.

The NPSHR for each pump type is given in the sheets of characteristic curves. See chapter 6.2.2. for the required inlet height (minimum water depth of coverage above the suction strainer). Consider thereby the related maximum velocity of flow between pump and borehole. At higher speeds the required flow level above the NPSH value must be redetermined.

Independent of the required flow level which is above the NPSH value, the flow rate must never be less than 1,2 m (danger of air sucking turbulences). This applies to both horizontal and vertical installation.

Minimum flows

When starting against closed pressure valves but also when operating at partial capacity around zero flow almost all the power taken up is converted to heat. If the required minimum capacity is not reached, then this can cause serious damage to the pump unit within a very short period of time. After the pump has reached operating speed, the pressure side valve should therefore be opened as quickly as possible. On average, minimum capacity is about 10% of the design amount. We are happy to supply more detailed information on request.

Maximum flows

The allowed operating range must comply with the given of the order confirmation to secure trouble-free operation. The maximum flow rates may not be exceeded even temporarily. Otherwise damage may be caused due to cavitation or reversal of the axial thrust.

Installation position

Vertical and horizontal installation is allowed. The maximum operating flow must be kept. The pump design is with or without integrated non-return valve (at vertical or horizontal installation).

Protection against running dry

The pumps must not run dry under any circumstances (not even for a short time for the purpose of checking the direction of rotation), since overheating can damage pump components. Therefore we recommend monitoring the required minimum water level in order to protect the pump.

2. Description

2.1 Models

Z8*/ZR8* Submersible pump for wells with 8"-
Z10*/ZR10* 12" bore.
Z12*/ZR12*

Please see the Appendices for the sectional drawings and index of parts for each pump.

The detailed designation of the pump is shown on the pump nameplate or the order confirmation.

2.2 Pipe Connection

pipe connection	internal thread
Z8*/ZR8*	Rp5 ÖNORM EN 10226
Z10*/ZR10*	Rp6 ÖNORM EN 10226
Z12*/ZR12*	API 8" NPT

Other pipe connections are executed optionally on customer request and are seen in the order confirmation.

3. Transport, Handling, Storage

3.1 Transport, Handling

- Check the pump/pump unit immediately upon delivery/receipt of despatch for damage or missing parts.
- The pump/pump unit must be transported carefully and by competent personnel. Avoid serious impacts.
- Keep the pump/pump unit in the same position in which it was supplied from the factory. Take note of the instructions on the packaging.
- The intake and discharge side of the pump must be closed with plugs during transport and storage.

 Dispose of all packing materials in accordance with local regulations.

- Lifting aids (stacker, crane, crane mounting device, lifting blocks, sling ropes, etc.) must have the proper dimensions so that they can bear the weight of the pump, motor and the pressure line when it is full of water.
- The pump/pump unit may only be lifted by solid points. The following illustration shows the correct method of carrying by crane.

Pump Backflow

It is not permissible to drain the pressure line after the pump has been switched off as the backflow speed can be many times the operating speed and would destroy the unit. A backflow through the pump can be prevented by suitable non-reflux fittings as close to the pump as possible insofar as a non-return valve are not installed in the pump.

2.3 Bearings

The pump shaft is maintained multiple in maintenance-free plain bearings.

2.4 Motor



The motor of your pump has its own Operating Instructions. It is vital that you read and comply with the instructions and safety instructions contained in them.

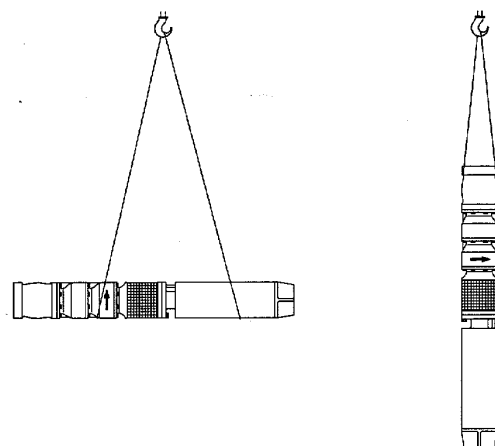

Under no circumstances may the unit be lifted on to the motor cable. Do not damage the cable during transport (do not squeeze, bend or drag). The cable ends must be kept dry.



Do not stand underneath suspended loads; take note of the general regulations on prevention of accidents.



The pump/pump unit must be secured against tipping over and slipping until it has been fixed in its final location.

3.2 Storage

If a pump or unit are to be stored for a long period before installation or after removal the pump must be

completely emptied. They must be stored in a dry, frost-resistant room. Protect from damp (especially cable ends), vibrations and dirt, e.g. by wrapping in oiled paper. The units must be stored standing (motor at the bottom). Secure so that it cannot fall over. Observe the Motor Cable's permitted bending radiuses, see Motor Operating Instructions.

4. Assembly, Operation

4.1 Preparing to install the unit

Necessary equipment for installation

- Lifting gear (lifting block or winch). This must be strong enough to bear the whole weight of the pump, motor, cable and pressure line when it is full.
- Support clamps. These must also be able to bear the whole weight of pump, motor, cable and the pressure line when it is full. Two identical pairs of support clamps are required for installation.
- Voltammeter and ammeter and insulation measuring device (e.g. megger) with direct current (at least 500 V measuring circuit voltage).

Fittings and Hydraulic Equipment

- Non-return valve. The non return valve is usually integrated in the pump delivery casing at pumps for vertical arrangement. If the pump is to be installed horizontally or if a pump was expressly ordered without an integrated non-return valve a suitable non-return device should be fitted as close to the pump as possible.
- Pressure valve. This is to be fitted in the pressure line to regulate the discharge.
- Pressure gauge with a stop valve. These are to be fitted between the pump and the pressure valves to control and regulate operating pressure.
- Water level indicator or low water protection. These are to control and supervise the minimum water level during operation.

If water levels fluctuate we recommend that you install a low water protection device. This device monitors the water level and if it sinks below permitted levels automatically turns the motor off.

4.2 Setting the Installation Depth

The depth of installation should be set with the help of the well or bore hole diagram.



The pump unit must not stand on the ground as it can be damaged by the weight of the pressure line.

The suction filter of the pump must have minimum coverage at the lowest service water level. For bore wells arrange the pump with its suction filter far enough above the filter pipe that it is certain that no sand can be sucked in. If, however, the pump is installed near the filter pipe or below the filter, pipe sand protection or a flow cover must be fitted.

The motor is cooled using well water. The required minimum flow speed on the motor outside lagging must be given during operations. Ensure that the unit hangs completely free in the water and does not touch the sand or mud at the bottom of the well.



For narrow bore holes we recommend that you plumb the bore hole with a dummy which exactly matches the pump to be sure that the pump will not get stuck or become damaged.

4.3 Pipes

The unit must hang freely on the pressure line below the lowest service water level. The carrying capacity and compression strength of the pipes must be set so that the weight of the unit including the cable, the weight of water content and the maximum operating pressure can be held with certainty.



When lifting the unit out of the well/bore hole pay special attention to the weight of the full pressure line!

Submersible pumps with threaded connections may only be held up against the uppermost pressure casing when screwing in the pipes to prevent the pump from turning and becoming damaged. To prevent the pump coming loose from the pipes the thread connections must be secured with a commercially available screw securer (Loctite, Omnifit or something similar). This also prevents possible crevice corrosion in the thread connection.

It is important that the flange gasket is centrally inserted and does not compress the free cross section of stream. Round off the edges of the flange or the recesses to avoid damage to the cables. The flange joints should be secured against loosening.

4.4 Coupling the Motor and Pump

(only when the pump and motor are delivered separately)



Protect the motor cable from damage.

- Remove any transport safety devices from the pump and motor.
- If the motor is only suitable for one direction of rotation check before installation that its direction of rotation corresponds to that of the pump. On the pump the direction of rotation is shown by a direction of rotation arrow, on the motor by an identification letter in the type designation (R =

direction of rotation right, L = direction of rotation left in an anti-clockwise direction looking at the motor end or the pump pressure supports) insofar as the motor is only approved for one direction of rotation. This designation does not apply to motors for both directions of rotation.

- Check shaft ends or coupling as well as centering and clean if necessary. Grease with lubricant.
- Place the pump on the vertically positioned motor and slide the coupling over the shaft. If necessary turn the pump coupling slightly so that the cog parts can fit together. Motors with more than 10" have a smooth motor end with a feather key.
- Tighten the suction casing of the pump with the four screws or nuts and secure against loosening (see chapter "Screw torque").
- Check if the pump casing's supporting plate is still well set on the motor flange after screwing.
- Check whether the pump shaft or pump coupling is still standing with no axial play on the motor shaft. Axially raise pump shaft and coupling in the direction of the pump and watch whether the shaft sinks back to the starting position.
- If there are any radial safety screws on the coupling tighten and secure them.
- Check whether the shaft can be rotated evenly.
- Mount suction filter and cables including protective covering sheet.

With units which are delivered completely mounted we recommend that you take off the suction filter before installation and check whether the shaft can be rotated evenly. Take off any transport safety devices first.

Screw torque

Screw Size	Screw torque in Nm (Dry threads)
1/2-20UNF-2B	60
M12	60
M16	150

4.5 Voltage and Frequency

Mains voltage and frequency must be compared with the values on the rating plate and must correspond.

4.6 Cables

Inspect the whole length of the cable and the cable connections for possible damage before installation. Repair faulty spots with shrink down plastic tubing or cast resin sleeves and then test the insulation resistance.



Protect the open cable ends from damp and dirt.



If the cable needs to be extended this must be done water tight in the well area by means of shrink down plastic tubing or cast resin sleeves. Other connections are only permitted in the well above the highest water level and are to be avoided if at all possible.

4.7 Measuring insulation value

The insulation value of the winding must be checked before installation. For more details see the Motor Operating Instructions.

4.8 Motor Filling

Pay attention to the Motor Operating Instructions and check whether the motor filling has to be checked, refilled or if the motor must be newly filled.

4.9 Lowering the unit

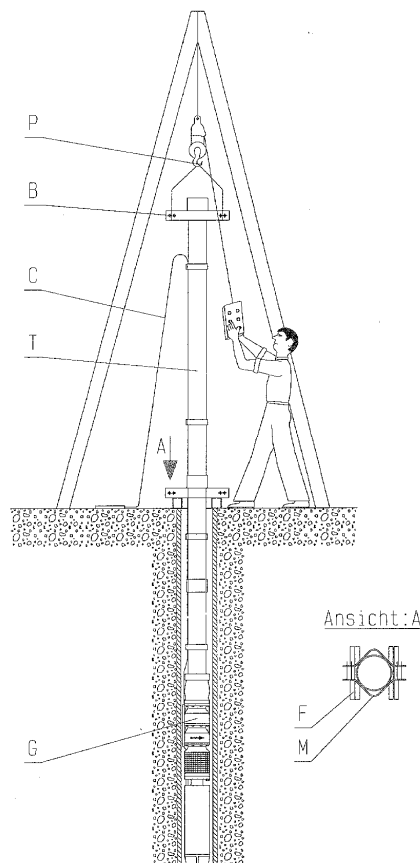

The suspension point (P) for the lifting gear and the support cable on the unit must be positioned so that the unit can be lowered centrally in the well or bore hole and that the unit will hang in exact vertical position.

The installed unit should hang free on the pressure line sufficiently below the deepest service water level. A support clamp which is supported by two transverse girders (F) in the well or on the opening of the well pipe holds the pressure line as well as the unit and cable. Pressure line, support clamp and transverse girders must be constructed so that they can bear the whole weight of the unit (G), the cable (C) and the full pipe (T) (also see Point 4.3 "Pipes"). During installation each of the support clamps (M and B) will be used alternatively to support and lower the pump screwed to the pressure line

When assembling the pressure line comply with Point 4.3 "Pipes".

Installation, Operating and Maintenance Instruction

Pay attention to cable "C" especially when counter-boring. It must be continually observed and must be carried loosely or tension free. Do not let it glide over edges or under any circumstances subject the cable to traction. Comply with the smallest permissible bending radius according to Point 3.2.

When using pressure lines with flanged joints the edges must be rounded carefully to prevent damage to the cable. Use flange joints with cable recesses in narrow bore holes.

When lowering, the cable must be attached loosely and tension free to the pressure line at distances of 2-3 m using cable clamps. Only use clamps made of rust-free material to avoid corrosion in the damp atmosphere of the well shaft.



Continually note the exact lengths of the individual lengths of pipes. This will enable you to lower the unit to the exact prescribed depth of installation.

After completing installation mount the support clamp which was attached last as holding clamp. Screws should be secured against loosening and the support clamp attached to their supports so that there is no torsion.

4.10 Dismantling

- All components must have cooled down to ambient temperature.
- The pump unit is dismantled using reverse procedure for assembly; see point 4.9 "Lowering the Unit".



Before starting to dismantle the pump unit make sure that it cannot be switched on again.

Water in the discharge pipe - remember the additional weight!

5. Electrical connection



Electrical connection work may only be carried out by an authorised professional. The rules and regulations valid for electrical technology, especially those concerned with safety measures, must be observed. The regulations of the national power supply companies operating in that area must also be observed.

The power supply cable must be connected to the terminals according to the circuit diagram in the Motor Operating Instructions.



Mount switching and monitoring devices in a dry, dust-free room.

5.2 Connecting the Cable

For optimal connection or the lowest possible contact resistance the cable ends may not be solder coated. Do not roll up excess cable lengths in reels as this can lead to impermissible increases in temperature due to induction.



Mount the unit's second rating plate which is attached to the end of the cable in the control cabinet. This will allow you to determine the type designation and production number of the unit at any time.



Due to the required coolness certain motor actuation cables may only be installed flooded - see Motor Operating Instructions.

5.1 Electrical Devices

The switching devices are directed by the kind of start selected as well as by the control of the pump. Take care that a reliable, rapid reaction motor protection device is fitted which will definitely be able to protect the motor from overloading. We recommend that you install a volt meter and an ammeter to monitor start-up and operations.

6. Start-up, Operation, Shut down



The plant may only be taken into operation by personnel who are familiar with local safety regulations and these Operating Instructions (especially with the safety regulations and safety instructions contained in them).

Initial start-up

- Check the setting of the excess current release for three phase motors.
- Measure the insulation values of the installed machine to make sure that the cable(s) was/were not damaged during installation.
- Check flooding of the pump (minimum water level) so that the pump will not run dry.
- If pressure lines are empty only start with closed valves so that the maximum permissible flow is not exceeded.

- Immediately after switching on or switching to running position the current consumption must fall to the level of the motor rated current as stated on the rating plate. The ammeter indicator must stand still.
- Checking the direction of rotation. After filling the pressure lines completely (check at the pressure gauge faucet), read the pressure on the pressure gauge when the pressure valves are almost closed. The pressure level shown on the pressure gauge plus the geodetic difference in level between the water level and the measuring point must correspond approximately to the delivery according to the pump characteristic curve in the range of zero flow rate. Otherwise the direction of rotation must be altered by interchanging two phases and then check the pressure again.

Motors which are only suitable for rotation in one direction should not be allowed to run in reverse for long. Pumps with single stage alternating current motors will certainly run in the proper direction if they are connected properly.

- During the pump test it is necessary to keep the plant under constant observation and to check the current consumption and discharge. For new wells or bore holes with unknown yield we recommend checking the fall in water level as well as the sand content of the water during the first period of operations. Excess sand content (more than 50 g/m³) can lead very quickly to wear and reduced output of the unit.
- After insulation values have been measured again after a few hours of operation the plant can be operated automatically. To obtain comparable values for winding resistance: Allow the motor to cool for at least one hour before measuring.

Restarting

Each time operations are restarted proceed as in initial operations. However, it is unnecessary to check the insulation values, the direction of rotation or to measure winding resistance.

6.1 Operation and Monitoring



Regular monitoring and maintenance will extend the life of your pump or system.

- You must observe the area of application given in the Confirmation of Order.
- Do not exceed the output given on the motor rating plate.
- Avoid dry running, running against closed discharge valves.
- Pay attention to the permitted number of starts.

6.2 Limits of Operation



The operating limits of the pump / unit regarding pressure, temperature, performance and speed are shown in the data sheet and / or order confirmation and must be observed under any circumstances!

- Do not exceed the output given on the motor name plate.

6.2.1 Flow min. / max.

If no other data are given in the curves or data sheets, the following is valid:

Pump Size	Recommended minimum flow for continuous operation [m ³ /h]	
	50 Hz	60 Hz
Z8-ZR855...	10	12
Z8-ZR875...	15	18
Z8-ZR895...	22	27
Z8-ZR8125...	30	36
Z10-ZR10150...	40	50
Z10-ZR10200...	60	80
Z10-ZR10275...	80	100

Z12-ZR12340...	150	180
Z12-ZR12420...	200	-

Pump Size	Maximum flow [m ³ /h] for vertical and horizontal installation	
	50 Hz	60 Hz
Z8-ZR855...	75	90
Z8-ZR875...	105	125
Z8-ZR895...	135	160
Z8-ZR8125...	170	200
Z10-ZR10150...	200	240
Z10-ZR10200...	250	280
Z10-ZR10275...	320	360
Z12-ZR12340...	400	400
Z12-ZR12420...	520	-

Values are valid under the requirement $NPSH_{Plant} > (NPSH_{Pump} + 0,5 \text{ m})$

6.2.2 Minimum depth of coverage

Pump Size	U _{min}	
	mm	...refers to a velocity of water of max. ...m/s in the case space between the pump and well casing.
Z8-ZR855...	1000	4,2
Z8-ZR875...		
Z8-ZR895...		
Z8-ZR8125...		
Z10-ZR10150...	1600	4,5
Z10-ZR10200...	2900	
Z10-ZR10275...		
Z12-ZR12340...	2900	
Z12-ZR12420...		

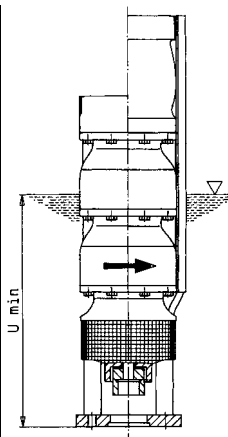

6.2.3 Permitted number of starts

With electric motors, the permitted number of starts is given in the attached motor operating instructions. If there are not specified values for the operating cycles in the motor instruction manual, then the values of diagram 1 are valid.

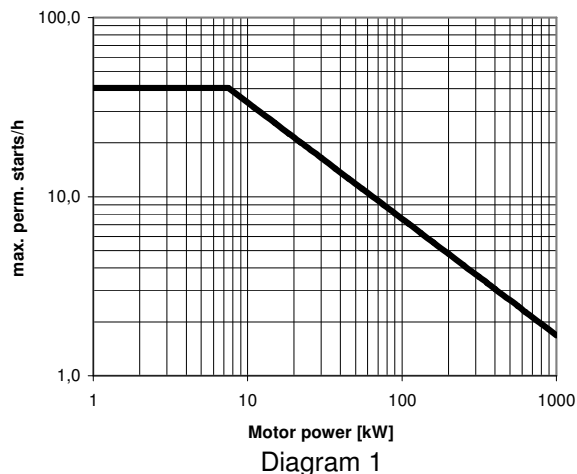

If two different figures are given, the lower figure is valid.

6.3 Shutting down

- Close the valve in discharge pipe right before (max. 10 seconds) switching off the motor. This is not necessary if there is a spring-loaded check valve.
- Switch off motor (make sure it runs down quietly).

7. Maintenance, Servicing



Work should only be carried out on the pump or pump unit when it is not in operation. You must observe Point 1.4 "Safety instructions".



Maintenance and servicing work must only be carried out by trained, experienced staff who are familiar with the contents of these Operating Instructions, or by the Manufacturer's own service staff.

The submersible pump requires virtually no maintenance. Inspection work is limited to the periodical measuring of insulating resistance (once every 2 years, recommended once per year when the motor is cold) as well as regular checking of the operating voltage, current consumption and the flow data. We recommend that you record and compare these data in the "Log Book". The development of this

data can perhaps make it possible to recognize damage early on thus making it possible to avoid greater damage or even complete destruction.

Slow reduction of the flow rate at the same discharge level, with normal or reduced current consumption indicates increased wear and tear of the pump components (e.g. through sand). A large increase or fluctuations in current consumption indicate a mechanical fault (e.g. increased mechanical friction due to a defective bearing). The unit should be taken out of operation immediately to prevent greater damage.



The electrical devices should be inspected annually by a specialist to see that they function properly.

8. Longer periods of non-operation



When starting up, follow the instructions for starting up for the first time (see Point 6)!

Check insulation resistance of installed units at monthly intervals and carry out a short trial run to

prevent the pump part getting stuck due to sediments. The minimum flooding of the unit must be guaranteed during this process.

9. Faults - Causes and Solutions

The following notes on causes of faults and how to repair them are intended as an aid to recognising the problem. The manufacturer's Customer Service Department is available to help repair faults that the operator cannot or does not want to repair. For repair

and modification of the pump by the customer pay attention to the design data of the order confirmation as well as to point 1.2 - 1.4 of this instruction manual. If necessary, the written agreement of the manufacturer must be obtained.

Faults	Code no. for cause and method of repair
Motor protection switches itself off	1, 2, 10
Electricity consumption too high. Releases motor protection.	2, 3, 4, 5, 6, 7, 24
Pump does not start	2, 3, 5, 7, 8, 9, 10
Pump runs but does not transport	11, 12, 13, 14
Output too low	15, 16, 17, 18, 19, 20, 21, 22, 23

Meaning of code number for cause and method of repair

1. Motor protection switch is wrongly set
 - Check setting or replace the motor protection switch
2. Phase failure
 - replace defective safety fuses
 - Check pipes for damage
3. Wrong frequencies or under voltage
 - Compare voltage and frequency with data on the rating plate
4. Rotates in the wrong direction
 - Swap over phases of power supply

5. Motor winding or electrical cable defective
 - Ask for assistance
6. Motor gets caught at the star delta at the star stage
 - Replace star delta converter
7. Voltage loss due to burned out safety fuse
 - Replace safety fuse
8. Voltage loss due to defective feeding cables
 - Renew cables
9. Voltage loss due to motor protection switch being released
 - Establish the causes
 - Reset the motor protection switch
10. Pump is blocked due to impurities
 - Dismantle and clean the pump part
11. Pump does not reach the handled liquid due to it not being installed deeply enough
 - Check the water level
 - Hang the unit deeper
12. Defective coupling
 - Replace shaft and coupling
13. Gate valve closed
 - open
14. Suction filter displaced by foreign bodies
 - Take out pump and clean the suction filter
15. uninspected, wrong direction of rotation
 - change direction of rotation
16. Gate valve not quite open
 - open
17. Pipes constricted by foreign bodies
 - clean pipes
18. Well filter blocked
 - Consult well sinker company
19. Leakage in the delivery pipe
Check pipes
20. Impellers worn because liquid handled is aggressive or contains sand
 - Dismantle unit and replace the impellers (be careful when selecting material)
21. Impellers worn due to cavitation
 - Check operating conditions
22. too little speed due to under voltage or wrong frequencies
 - Check mains voltage and mains frequency
23. too little speed because running in 2 phases
 - check electrical branch circuit connections and safety fuses
24. Flow rate too high or too low
 - Adjust valve

10. Repairs



Repairs to the pump or pump system may only be carried out by authorized skilled personnel or by the manufacturer's specialist staff.

Trained Customer Service engineers are available to assist with installation and repair work on request.

When removing the pump or the motor, you must comply with Point 1.4 "Safety instructions", Point 3.1 "Transport, Handling" and Point 6.3 "Shutting down".

11. Spare parts, Reserve pumps

11.1 Spare parts

Spare parts should be selected to last for two years of continuous operation. If no other guidelines are

applicable we recommend that you stock the number of parts listed below (in accordance with DIN 24296).



To ensure optimum availability, we recommend that suitable quantities of spare parts are held in stock, especially if these are made from special materials because of the longer delivery times.

Number of Spare Parts

Spare Parts	P						
	1 - 2	3	4	5	6 - 7	8 - 9	10/more
Impeller	1 x N	1 x N	1 x N	2 x N	2 x N	3 x N	0,3 x N x P
Guide wheel or multi-stage casing	0,5 x N	0,5 x N	0,5 x N	1 x N	1 x N	1,5 x N	0,15 x N x P
Joints for pump casing sets	4	6	8	8	9	12	0,15 x N x P
Bearing bush sets	2	2	2	3	3	4	0,5 x N x P
Bushing (if present)	2	2	2	3	3	4	0,3 x N x P
Shaft	1	1	2	2	2	3	0,3 x N x P
Non-return valve	1	1	2	2	2	3	0,3 x N x P
Other joints sets	4	6	8	8	9	10	1 x N x P

P = Number of pumps (incl. stand-by pumps)

N = Number of steps

Ordering spare parts

When ordering spare parts, please supply the following information:

- Type: _____
- Order no.: _____
- Sectional drawing: _____
- Part designation: _____

All the information is given in the relevant sectional drawing.

11.2 Reserve pumps



It is essential that a sufficient number of stand-by pumps are kept ready for use in plants where failure of a pump could endanger human life or cause damage to property or high costs. Regular checks should be carried out to ensure that such pumps are always ready for use (see Point 8).

Baugrößen: Z8*/ZR8*
Taille:
Size:

Standardausführung: mit Rückschlagventil
Standardausführung: avec clapet de retenue
Standardausführung: with non return valve

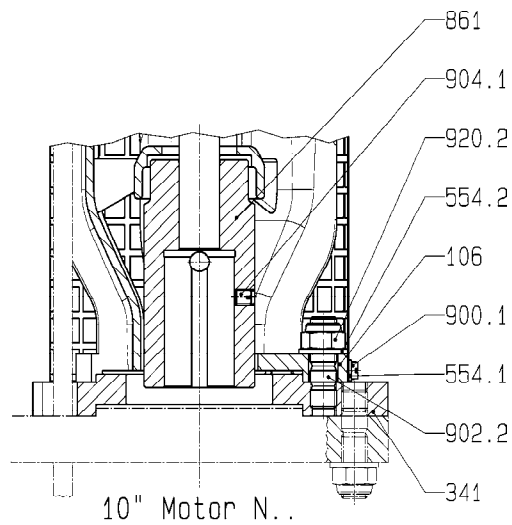
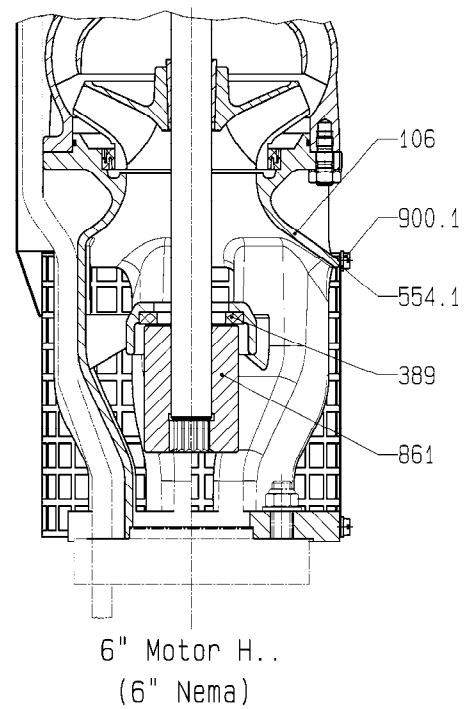
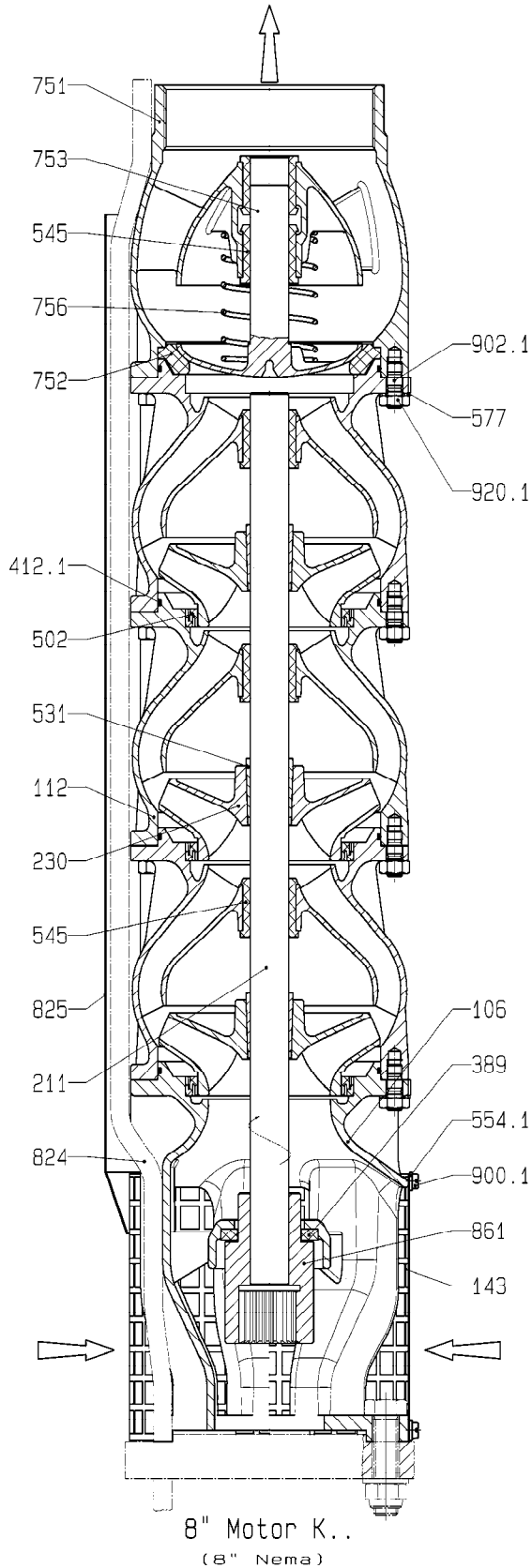

Technische Änderungen vorbehalten! - Modifications techniques sans preavis! - This leaflet is subject to alternation without notice!

Nr.	Teilbezeichnung	Nomenclature	Index of Parts
106	Sauggehäuse	Corps d'aspiration	Suction casing
112	Leitschaukelgehäuse	Corps redresseur	Pump bowl
143	Saugsieb	Crépine d'aspiration	Suction strainer
211	Welle	Arbre	Shaft
230	Laufgrad	Roue	Impeller
341	Motoradapter	Lanterne-support de moteur	Motor stool
389	Gegenspurlager	Butée d'arbre	Shaft thrust bearing
412.1	O-Ring	Joint torique	O-ring
502	Spaltring	Bague d'usure	Casing wear ring
531	Spannhülse	Douille de serrage	Locking sleeve
545	Lagerbuchse	Coussinet	Bearing bush
554.1	Unterlegscheibe	Rondelle	washer
554.2	Unterlegscheibe	Rondelle	washer
577	Klemmblech	Tôle à bornes	Clamping plate
751	Ventilgehäuse	Corps de clapet	Valve body
752	Ventilsitz	Siège de soupape	Valve seat
753	Ventilkegel	Soupape du clapet de retenue	Wing valve
756	Ventilfeder	Ressort de soupape	Valve spring
824	Motorkabel	Moteur câble	Motor cable
825	Kabelschutzblech	Protège- câble	Cable guard
861	Kupplung	Accouplement	Coupling
900.1	Schraube	Vis	Screw
902.1	Stiftschraube	Goujon	Stud
902.2	Stiftschraube	Goujon	Stud
904.1	Gewindestift	Vis d'arrêt	Grub screw
920.1	Sechskantmutter	Ecrou	Hexagonal nut
920.2	Sechskantmutter	Ecrou	Hexagonal nut

Baugrößen: Z8*/ZR8*
Taille:
Size:

optionale Ausführung: mit Druckgehäuse
optionale Ausführung: avec corps de refoulement
optionale Ausführung: with delivery casing

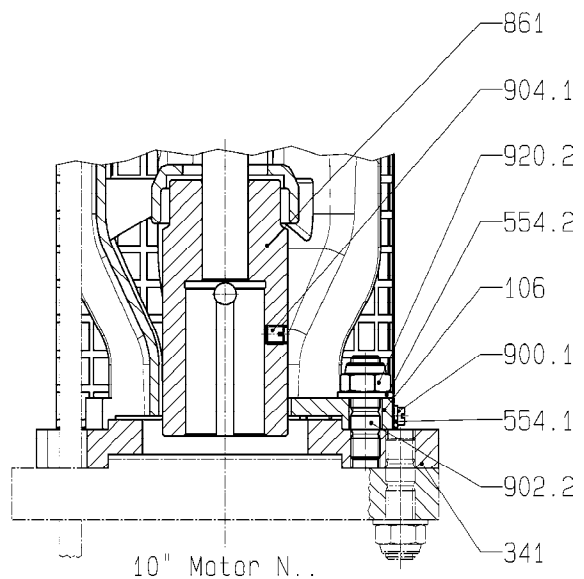
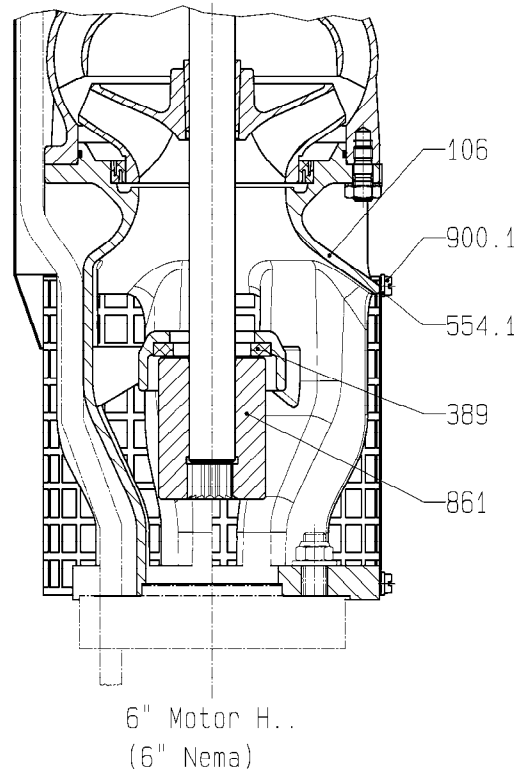
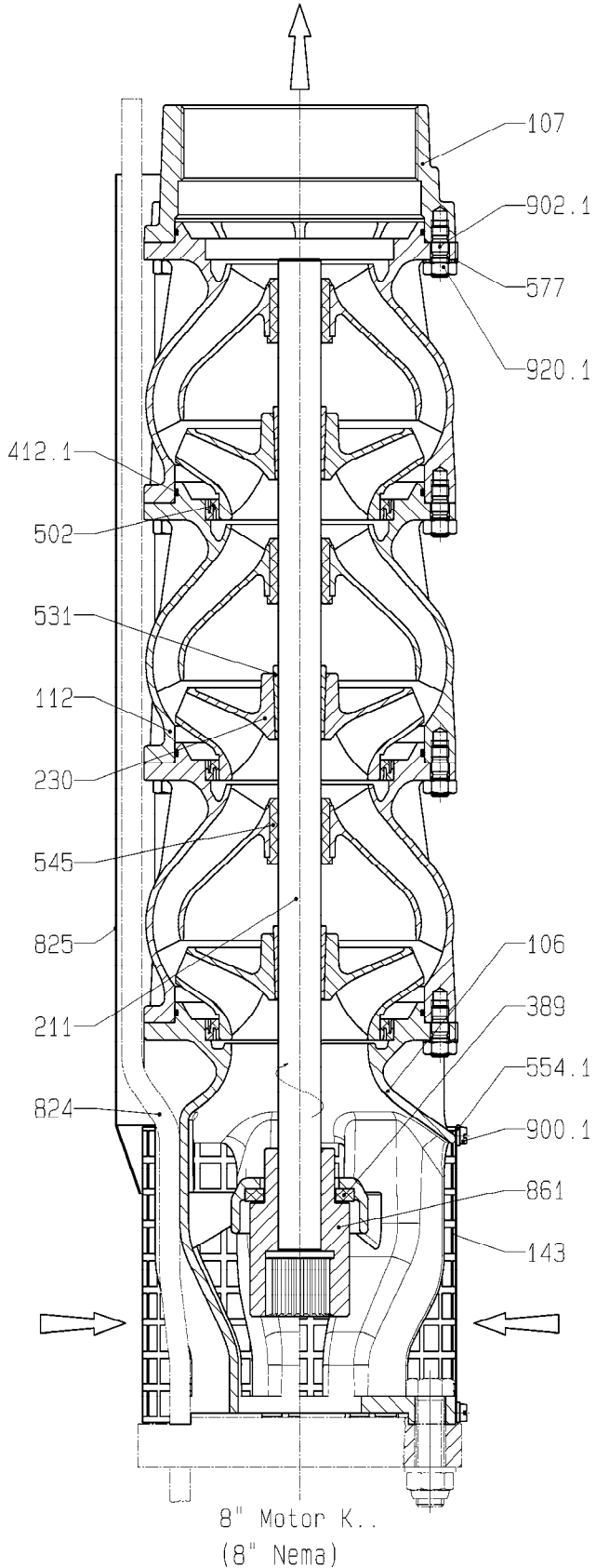

Technische Änderungen vorbehalten! - Modifications techniques sans preavis! - This leaflet is subject to alternation without notice!

Nr.	Teilbezeichnung	Nomenclature	Index of Parts
106	Sauggehäuse	Corps d'aspiration	Suction casing
107	Druckgehäuse	Corps de refoulement	Discharge casing
112	Leitschaufelgehäuse	Corps redresseur	Pump bowl
143	Saugsieb	Crépine d'aspiration	Suction strainer
211	Welle	Arbre	Shaft
230	Lauftrad	Roue	Impeller
341	Motoradapter	Lanterne-support de moteur	Motor stool
389	Gegenspurlager	Butée d'arbre	Shaft thrust bearing
412.1	O-Ring	Joint torique	O-ring
502	Spaltring	Bague d'usure	Casing wear ring
531	Spannhülse	Douille de serrage	Locking sleeve
545	Lagerbuchse	Coussinet	Bearing bush
554.1	Unterlegscheibe	Rondelle	washer
554.2	Unterlegscheibe	Rondelle	washer
577	Klemmblech	Tôle à bornes	Clamping plate
824	Motorkabel	Moteur câble	Motor cable
825	Kabelschutzblech	Protège- câble	Cable guard
861	Kupplung	Accouplement	Coupling
900.1	Schraube	Vis	Screw
902.1	Stiftschraube	Goujon	Stud
902.2	Stiftschraube	Goujon	Stud
904.1	Gewindestift	Vis d'arrêt	Grub screw
920.1	Sechskantmutter	Ecrou	Hexagonal nut
920.2	Sechskantmutter	Ecrou	Hexagonal nut

Baugrößen:
Taille: Z10*/ZR10*
Size:

Standardausführung: mit Rückschlagventil
Standardausführung: avec clapet de retenue
Standardausführung: with non return valve

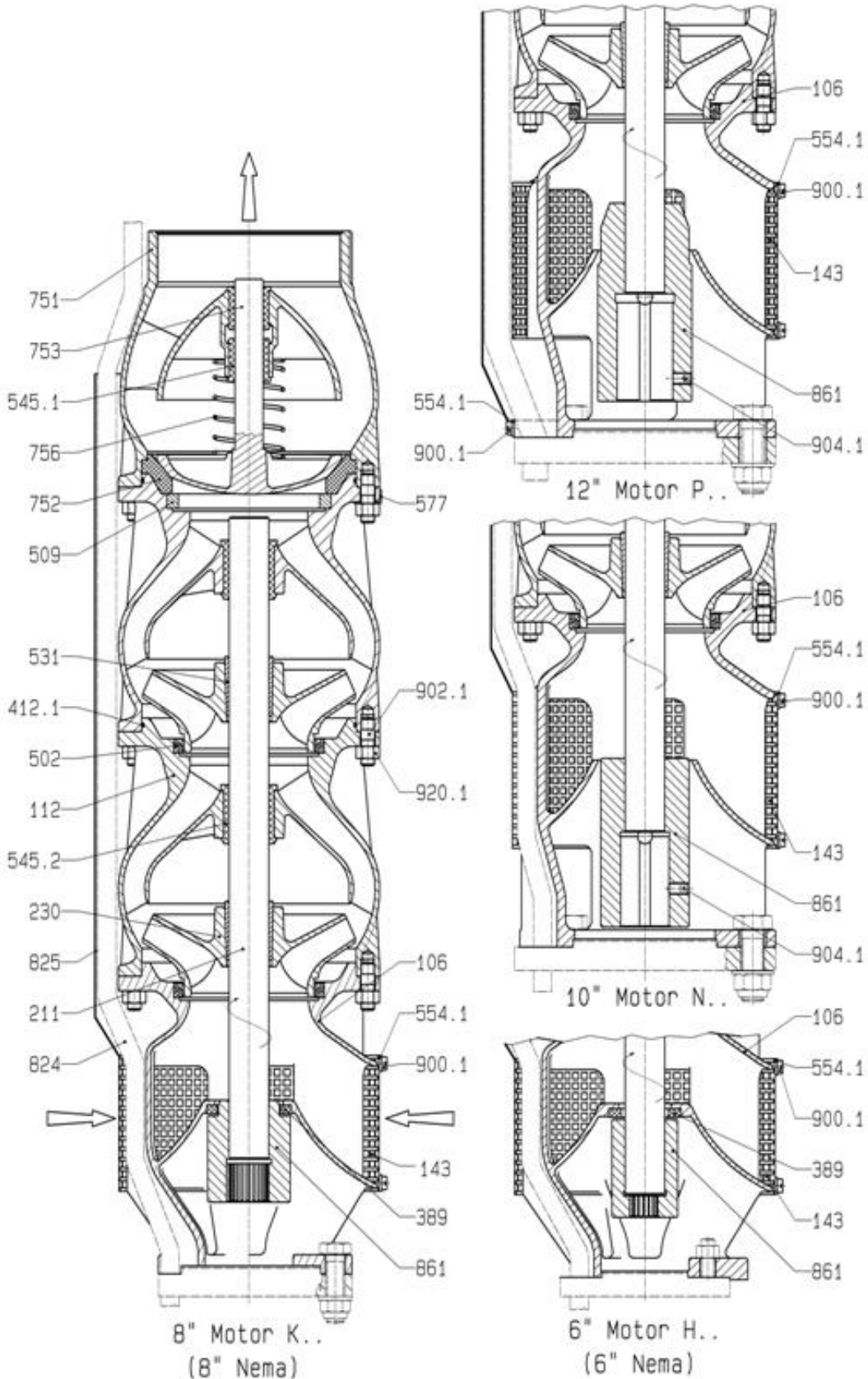

Technische Änderungen vorbehalten! - Modifications techniques sans preavis! - This leaflet is subject to alternation without notice!

Nr.	Teilbezeichnung	Nomenclature	Index of Parts
106	Sauggehäuse	Corps d'aspiration	Suction casing
112	Leitschaukelgehäuse	Corps redresseur	Pump bowl
143	Saugsieb	Crépine d'aspiration	Suction strainer
211	Welle	Arbre	Shaft
230	Lauftrad	Roue	Impeller
389	Gegenaxialagerring	Grain fixe de contre-butée	Up thrust bearing ring
412.1	O-Ring	Joint torique	O-ring
502	Spaltring	Bague d'usure	Casing wear ring
509	Zwischenring	Bague de raccordement	Intermediate ring
531	Spannhülse	Douille de serrage	Locking sleeve
545.1	Lagerbuchse	Coussinet	Bearing bush
545.2	Lagerbuchse	Coussinet	Bearing bush
554.1	Unterlegscheibe	Rondelle	washer
577	Klemmblech	Tôle à bornes	Clamping plate
751	Ventilgehäuse	Corps de clapet	Valve body
752	Ventilsitz	Siège de soupape	Valve seat
753	Ventilkegel	Soupape du clapet de retenue	Wing valve
756	Ventilfeder	Ressort de soupape	Valve spring
824	Motorkabel	Moteur câble	Motor cable
825	Kabelschutzblech	Protège- câble	Cable guard
861	Kupplung	Accouplement	Coupling
900.1	Schraube	Vis	Screw
902.1	Stiftschraube	Goujon	Stud
904.1	Gewindestift	Vis d'arrêt	Grub screw
920.1	Sechskantmutter	Ecrou	Hexagonal nut

Baugrößen: Z10*/ZR10*
Taille:
Size:

optionale Ausführung: mit Druckgehäuse
optionale Ausführung: avec corps de refoulement
optionale Ausführung: with delivery casing

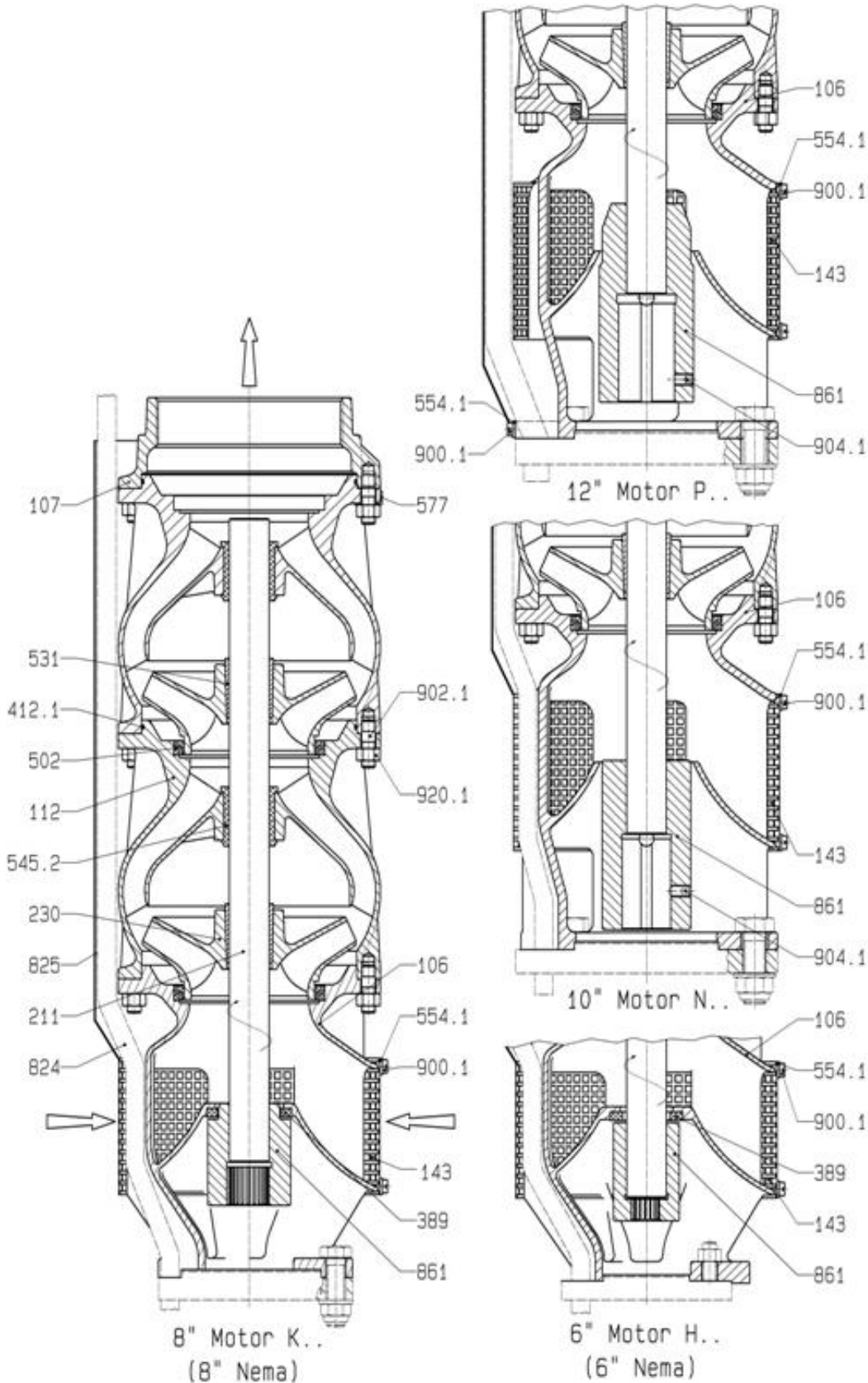

Technische Änderungen vorbehalten! - Modifications techniques sans preavis! - This leaflet is subject to alternation without notice!

Nr.	Teilbezeichnung	Nomenclature	Index of Parts
106	Sauggehäuse	Corps d'aspiration	Suction casing
107	Druckgehäuse	Corps de refoulement	Delivery casing
112	Leitschaufelgehäuse	Corps redresseur	Pump bowl
143	Saugsieb	Crépine d'aspiration	Suction strainer
211	Welle	Arbre	Shaft
230	Lauftrad	Roue	Impeller
389	Gegenaxialagerring	Grain fixe de contre-butée	Up thrust bearing ring
412.1	O-Ring	Joint torique	O-ring
502	Spaltring	Bague d'usure	Casing wear ring
531	Spannhülse	Douille de serrage	Locking sleeve
545.1	Lagerbuchse	Coussinet	Bearing bush
545.2	Lagerbuchse	Coussinet	Bearing bush
554.1	Unterlegscheibe	Rondelle	washer
577	Klemmblech	Tôle à bornes	Clamping plate
751	Ventilgehäuse	Corps de clapet	Valve body
752	Ventilsitz	Siège de soupape	Valve seat
753	Ventilkegel	Soupape du clapet de retenue	Wing valve
756	Ventilfeder	Ressort de soupape	Valve spring
824	Motorkabel	Moteur câble	Motor cable
825	Kabelschutzblech	Protège- câble	Cable guard
861	Kupplung	Accouplement	Coupling
900.1	Schraube	Vis	Screw
902.1	Stiftschraube	Goujon	Stud
904.1	Gewindestift	Vis d'arrêt	Grub screw
920.1	Sechskantmutter	Ecrou	Hexagonal nut

Baugrößen: Z12*/ZR12*
Taille:
Size:

Standardausführung: mit Rückschlagventil
Standardausführung: avec clapet de retenue
Standardausführung: with non return valve

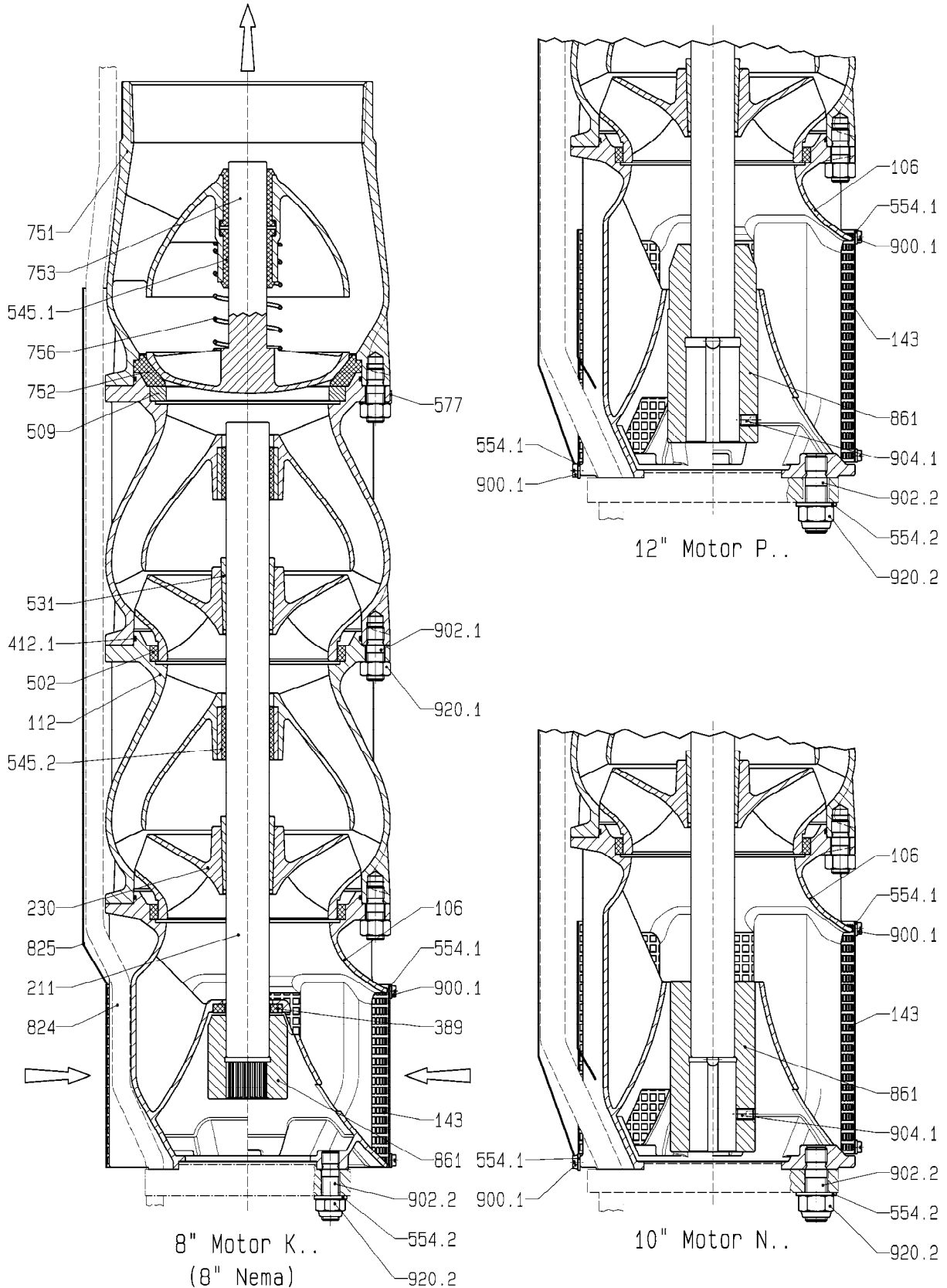

Technische Änderungen vorbehalten! - Modifications techniques sans preavis! - This leaflet is subject to alternation without notice!

Nr.	Teilbezeichnung	Nomenclature	Index of Parts
106	Sauggehäuse	Corps d'aspiration	Suction casing
112	Leitschaukelgehäuse	Corps redresseur	Pump bowl
143	Saugsieb	Crépine d'aspiration	Suction strainer
211	Welle	Arbre	Shaft
230	Lauftrad	Roue	Impeller
389	Gegenaxialagerring	Grain fixe de contre-butée	Up thrust bearing ring
412.1	O-Ring	Joint torique	O-ring
502	Spaltring	Bague d'usure	Casing wear ring
509	Zwischenring	Bague de raccordement	Intermediate ring
531	Spannhülse	Douille de serrage	Locking sleeve
545.1	Lagerbuchse	Coussinet	Bearing bush
545.2	Lagerbuchse	Coussinet	Bearing bush
554.1	Unterlegscheibe	Rondelle	washer
554.2	Unterlegscheibe	Rondelle	washer
577	Klemmblech	Tôle à bornes	Clamping plate
751	Ventilgehäuse	Corps de clapet	Valve body
752	Ventilsitz	Siège de soupape	Valve seat
753	Ventilkegel	Soupape du clapet de retenue	Wing valve
756	Ventilfeder	Ressort de soupape	Valve spring
824	Motorkabel	Moteur câble	Motor cable
825	Kabelschutzblech	Protège- câble	Cable guard
861	Kupplung	Accouplement	Coupling
900.1	Schraube	Vis	Screw
902.1	Stiftschraube	Goujon	Stud
902.2	Stiftschraube	Goujon	Stud
904.1	Gewindestift	Vis d'arrêt	Grub screw
920.1	Sechskantmutter	Ecrou	Hexagonal nut
920.2	Sechskantmutter	Ecrou	Hexagonal nut

Baugrößen: Z12*/ZR12*
Taille:
Size:

optionale Ausführung: mit Druckgehäuse
optionale Ausführung: avec corps de refoulement
optionale Ausführung: with delivery casing

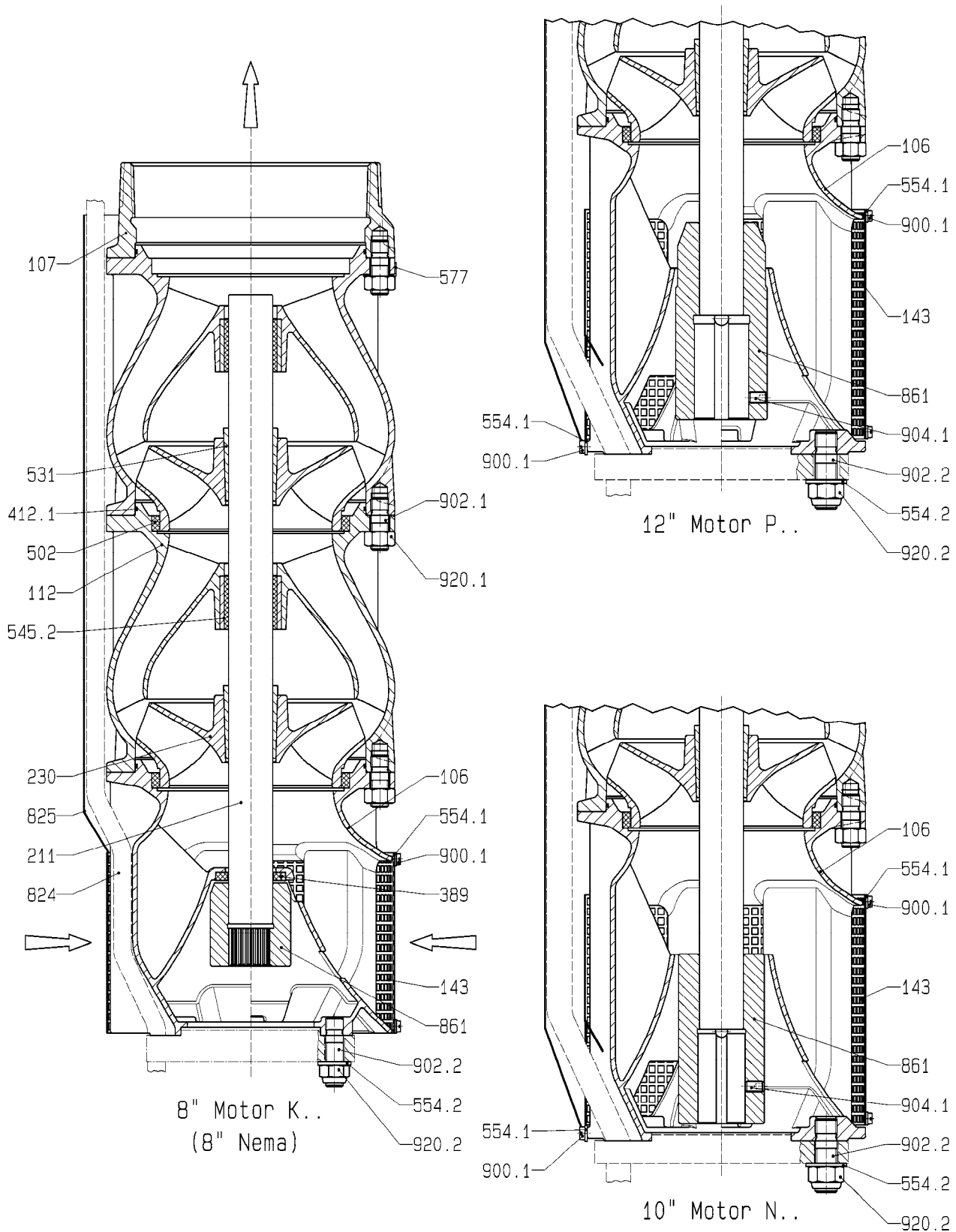

Technische Änderungen vorbehalten! - Modifications techniques sans preavis! - This leaflet is subject to alternation without notice!

Nr.	Teilbezeichnung	Nomenclature	Index of Parts
106	Sauggehäuse	Corps d'aspiration	Suction casing
107	Druckgehäuse	Corps de refoulement	Delivery casing
112	Leitschaufelgehäuse	Corps redresseur	Pump bowl
143	Saugsieb	Crépine d'aspiration	Suction strainer
211	Welle	Arbre	Shaft
230	Lauftrad	Roue	Impeller
389	Gegenaxiallagerring	Grain fixe de contre-butée	Up thrust bearing ring
412.1	O-Ring	Joint torique	O-ring
502	Spaltring	Bague d'usure	Casing wear ring
531	Spannhülse	Douille de serrage	Locking sleeve
545.1	Lagerbuchse	Coussinet	Bearing bush
545.2	Lagerbuchse	Coussinet	Bearing bush
554.1	Unterlegscheibe	Rondelle	washer
554.2	Unterlegscheibe	Rondelle	washer
577	Klemmblech	Tôle à bornes	Clamping plate
751	Ventilgehäuse	Corps de clapet	Valve body
752	Ventilsitz	Siège de soupape	Valve seat
753	Ventilkegel	Soupape du clapet de retenue	Wing valve
756	Ventilfeder	Ressort de soupape	Valve spring
824	Motorkabel	Moteur câble	Motor cable
825	Kabelschutzblech	Protège- câble	Cable guard
861	Kupplung	Accouplement	Coupling
900.1	Schraube	Vis	Screw
902.1	Stiftschraube	Goujon	Stud
902.2	Stiftschraube	Goujon	Stud
904.1	Gewindestift	Vis d'arrêt	Grub screw
920.1	Sechskantmutter	Ecrou	Hexagonal nut
920.2	Sechskantmutter	Ecrou	Hexagonal nut

de Konformitätserklärung

Lowara srl. mit Sitz in Montecchio Maggiore, Vicenza, Italien, erklärt, dass die nachfolgend beschriebenen Produkte

Tauchpumpen der Baureihen Z8, ZR8, Z10, ZR10, Z12, ZR12

den Vorschriften der folgenden europäischen Richtlinien und nationalen Durchführungsbestimmungen:

- Maschinenrichtlinie 2006/42/EG
- sowie den folgenden technischen Vorschriften entsprechen:
- EN 809, EN ISO 12100-1, EN ISO 12100-2, EN 60204-1

fr Déclaration de conformité

Lowara srl, ayant son siège à Montecchio Maggiore - Vicence - Italie, déclare que les produits décrits ci-après

pompes série Z8, ZR8, Z10, ZR10, Z12, ZR12

sont conformes aux dispositions des directives européennes et aux dispositions nationales de transposition suivantes

- Machines 2006/42/CE
- et sont conformes aux normes techniques suivantes
- EN 809, EN ISO 12100-1, EN ISO 12100-2, EN 60204-1

en Declaration of Conformity

Lowara srl, with headquarters in Montecchio Maggiore - Vicenza - Italy, hereby declares that the following products

Z8, ZR8, Z10, ZR10, Z12, ZR12 Series Pumps

comply with the provisions of the following European Directives and with the regulations transposing them into national law

- Machine Directive 2006/42/EC
- and with the following technical standards
- EN 809, EN ISO 12100-1, EN ISO 12100-2, EN 60204-1

it Dichiarazione di Conformità

La Lowara srl, con sede a Montecchio Maggiore - Vicenza - Italia, dichiara che i prodotti descritti sotto

pompe serie Z8, ZR8, Z10, ZR10, Z12, ZR12

sono conformi alle disposizioni delle seguenti direttive europee e alle disposizioni nazionali di attuazione

- Macchine 2006/42/CE
- e conformi alle seguenti norme tecniche
- EN 809, EN ISO 12100-1, EN ISO 12100-2, EN 60204-1

es Declaración de Conformidad

Lowara srl, con sede en Montecchio Maggiore - Vicenza - Italia, declara que los productos abajo descritos

bombas series Z8, ZR8, Z10, ZR10, Z12, ZR12

son conformes a las disposiciones de las siguientes directivas europeas y a las disposiciones nacionales de ejecución

- Máquinas 2006/42/CE
- y son conformes a las normas técnicas siguientes
- EN 809, EN ISO 12100-1, EN ISO 12100-2, EN 60204-1

pt Declaração de Conformidade

A Lowara srl, com sede em Montecchio Maggiore - Vicenza - Itália, declara que os produtos descritos a seguir:

bombas séries Z8, ZR8, Z10, ZR10, Z12, ZR12

estão conformes com as disposições das seguintes directivas europeias e as disposições nacionais de actuação

- Máquinas 2006/42/CE
- e conformes com as seguintes normas técnicas
- EN 809, EN ISO 12100-1, EN ISO 12100-2, EN 60204-1

Montecchio Maggiore, 29.006.2009

Amedeo Valente
(Director Engineering and R&D)





ITT

OOO "M3"

РФ, г. Москва

+7 495 22-66-208

www.m3-company.ru

info@m3-company.ru

Headquarters

LOWARA srl Unipersonale
Via Dott. Lombardi, 14
36075 Montecchio Maggiore
Vicenza - Italy
Tel. (+39) 0444 707111
Fax (+39) 0444 492166
e-mail: lowara.mkt@itt.com
<http://www.lowara.com>

ITT RESIDENTIAL AND COMMERCIAL WATER DIVISION - EMEA

MILANO

20090 Cusago - Viale Europa, 30
Tel. (+39) 02 90394188
Fax (+39) 0444 707176
e-mail: lowara.milano@itt.com

BOLOGNA

40132 - Via Marco Emilio Lepido, 178
Tel. (+39) 051 6415666
Fax (+39) 0444 707178
e-mail: lowara.bologna@itt.com

VICENZA

36061 Bassano del Grappa
Via Pigafetta, 6
Tel. (+39) 0424 566776 (R.A. 3 Linee)
Fax (+39) 0424 566773
e-mail: lowara.bassano@itt.com

PADOVA

35020 Albignasego
Via A. Volta, 56 - Zona Mandriola
Tel. (+39) 049 8801110
Fax (+39) 049 8801408
e-mail: lowara.bassano@itt.com

ROMA

00173 Via Frascineto, 8
Tel. (+39) 06 7235890 (2 linee)
Fax (+39) 0444 707180
e-mail: lowara.roma@itt.com

CAGLIARI

09122 - Via Dolcetta, 3
Tel. (+39) 070 287762 - 292192
Fax (+39) 0444 707179
e-mail: lowara.cagliari@itt.com

CATANIA

95027 S. Gregorio
Via XX Settembre, 75
Tel. (+39) 095 7123226 - 7123987
Fax (+39) 095 498902
e-mail: lowara.catania@itt.com

ITT Austria GmbH

A-2000 Stockerau
Ernst Vogel-Straße 2
Tel. (+43) 02266 604
Fax (+43) 02266 65311
e-mail: info.ittaustria@itt.com
<http://www.ittaustria.com>

LOWARA DEUTSCHLAND GMBH

Biebigheimer Straße 12
D-63762 Großostheim
Tel. (+49) 0 60 26 9 43 - 0
Fax (+49) 0 60 26 9 43 - 2 10
e-mail: lowarade.info@itt.com
<http://www.lowara.de>

LOWARA FRANCE S.A.S.

BP 57311
37073 Tours Cedex 2
Tel. (+33) 02 47 88 17 17
Fax (+33) 02 47 88 17 00
e-mail: lowarafr.info@itt.com
<http://www.lowara.fr>

LOWARA NEDERLAND B.V.

Zandweistraat 22
4181 CG Waardenburg
Tel. (+31) 0418 655060
Fax (+31) 0418 655061
e-mail: lowaranl.info@itt.com
<http://www.lowara.nl>

ITT PORTUGAL, Lda

Praceta da Castanheira, 38
4475-019 Barca
Tel. (+351) 22 9478550
Fax (+351) 22 9478570
e-mail: info.pt@itt.com
<http://www.itt.pt>

LOWARA UK LTD.

Millwey Rise, Industrial Estate
Axminster - Devon EX13 5HU UK
Tel. (+44) 01297 630200
Fax (+44) 01297 630270
e-mail: lowaraukenquiries@itt.com
<http://www.lowara.co.uk>

ITT IRELAND

50, Broomhill Close
Airton Road
Tallaght - DUBLIN 24
Tel. (+353) 01 4524444
Fax (+353) 01 4524795
e-mail: lowara.ireland@itt.com
<http://www.lowara.ie>

LOWARA VOGEL POLSKA Sp. z o.o.

PL 57-100 Strzelin
ul. Kazimierza Wielkiego 5
Tel. (+48) 071 769 3900
Fax (+48) 071 769 3909
e-mail: info.lowarapl@itt.com
<http://www.lowara-vogel.pl>

LOWARA Moscow

Kalanchevskaya st. 11 b. 2, off. 334
107078 Moscow
Tel. (+7) 495 631 55 15
Fax (+7) 495 631 59 72
e-mail: www.lowara.ru
<http://www.lowara.ru>

Engineered for life